

*To be adapted on site
 **Customized panel

Options

Frekv 1x230/240V 50-60Hz 16 A Soft
 Capacity: 300,00 kg

Approved by
 builder:

European view placement:



Positioning of machinery:

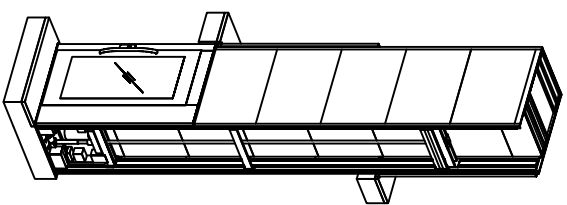
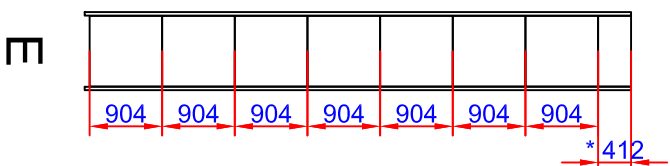
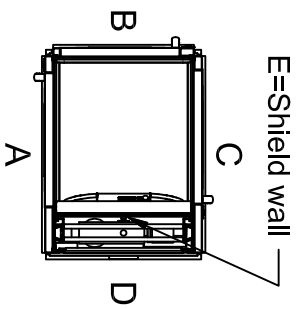

Tender no	Principal drawing		
Order no	A4000 - 1000*930		
Gen. Tolerances	Date	sheet	Scale:
SS-ISO 27681-1 m	2018-10-31	1 of 7	A3, 1:60

Shaft cutout sizes

Lift unit installed within a shaft by others

Recommended positioning of fixing points.

Loads per fixing point, F=250 N

Door front cutout sizes		
Landing	Width	Height
A 0	1430	2250
B 1	1043	2250
C 2	1430	2250

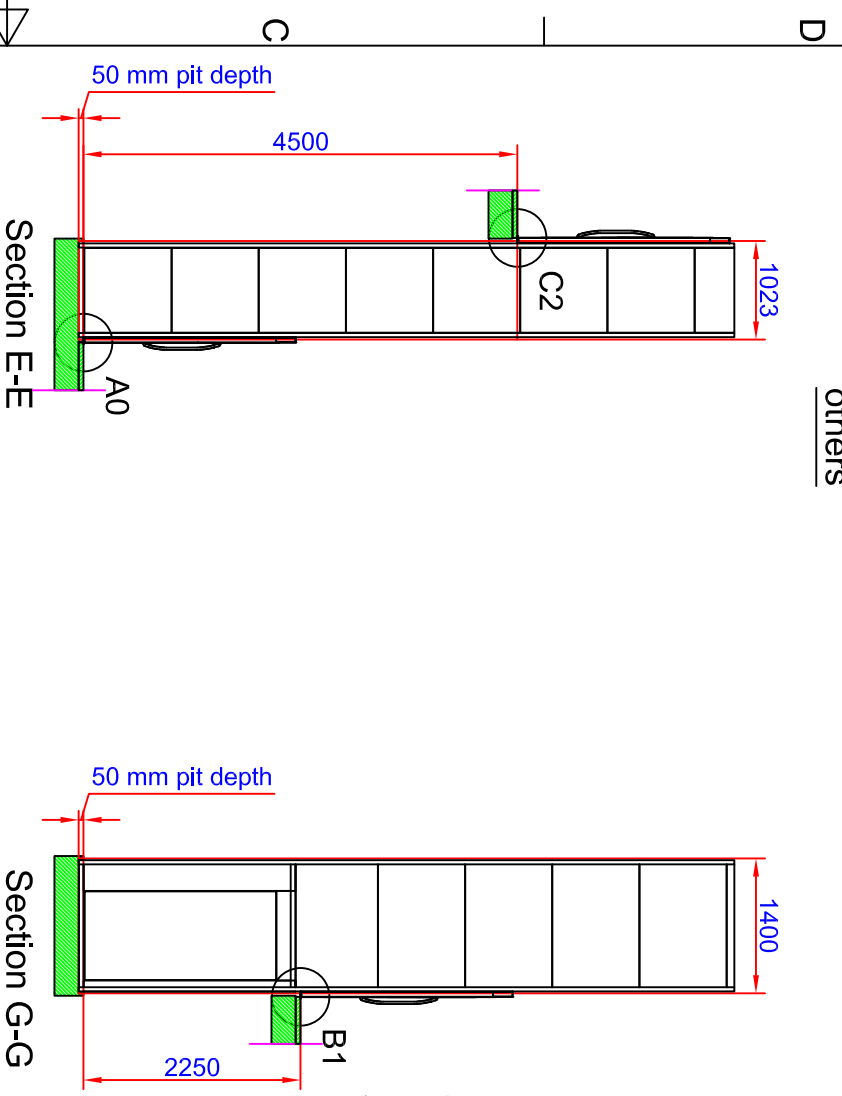

L section force: 6,54 kN
L section load: 21,44 kN/m²

Mast force: 8,32 kN
Mast load: 67,1 kN/m²

Loads sustained by shaft and platform and fixing points bottom frame

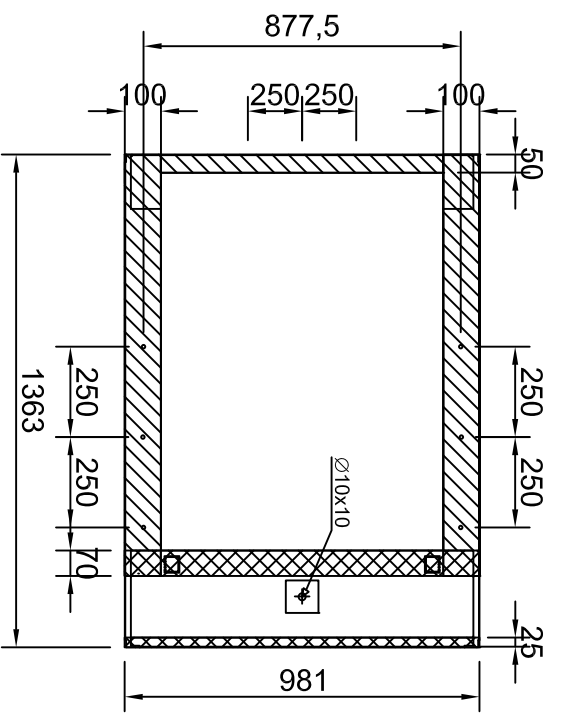

Scale: 1:20

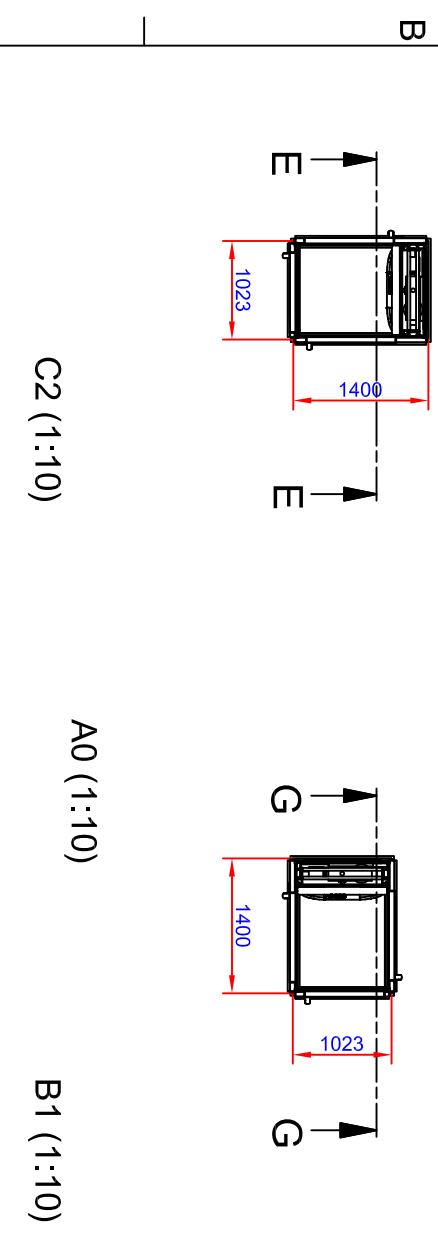
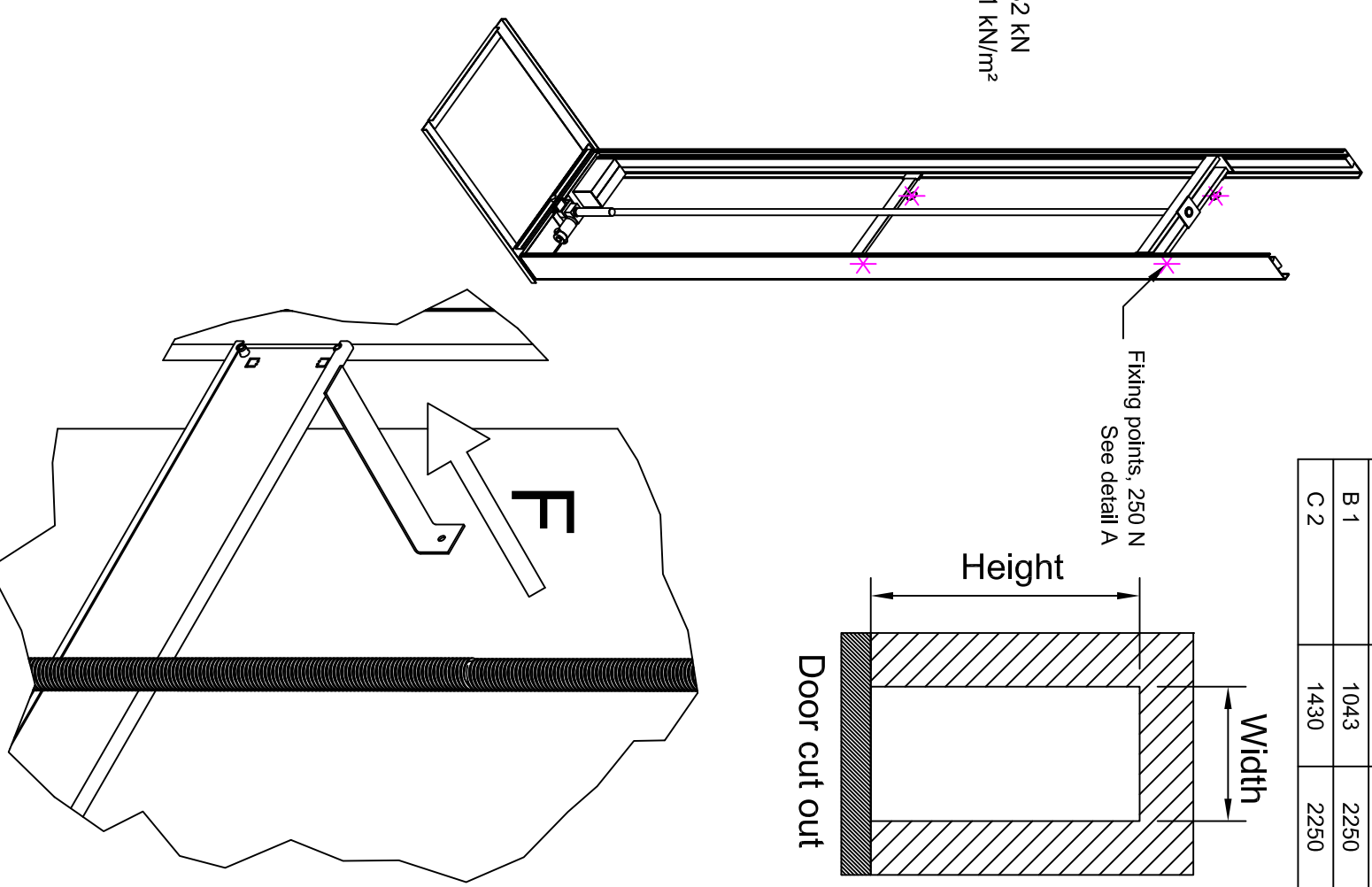

Approved by builder: _____
European view placement:

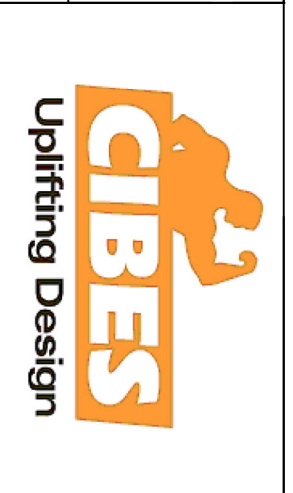

Tender no	A44000 - 1000*930	Principal drawing
Order no		Cut out sizes
Gen. Tolerances	SS-ISO 27681-1 m	Date
		2018-10-31
		Sheet
		2 of 7
		Scale:
		A3, 1:60